



# VibroSight® portable analyser

**VSPA**

## FEATURES

---

- » From the Vibro-Meter® product line
- » Portable condition monitoring system (CMS) based on proven VM600 system technology
- » Lightweight self-contained system with a rugged metal enclosure featuring an integrated hinged panel containing a full-size keyboard and touchpad
- » Powerful compact portable computer:
  - Intel® Core™ i7 processor
  - 8 GB RAM and 500 GB HDD
  - High-resolution 17.3" LCD display
  - Gigabit Ethernet
  - Spare expansion bays
  - Windows® 7 Professional (64-bit)
- » XMV16 / XIO16T extended vibration monitoring card pair:
  - 4 tachometer and 16 dynamic channels
  - Simultaneous data acquisition on all channels
  - Up to 20 outputs per channel
  - High-resolution FFT up to 6400 lines every 1 s
  - Asynchronous and synchronous sampling
  - 24-bit data acquisition and high SNR data-processing with quality checks
  - Fully software configurable
  - High-density connectors with spring-loaded connections
- » Gigabit Ethernet communications:
  - Internally to the XMV16 / XIO16T card pair
  - Externally to Ethernet networks
- » Latest versions of VibroSight® and associated database software pre-installed and configured
- » Supplied in a padded trolley case with integrated wheels and telescopic towing handle



**VibroSight portable analyser**



Information contained in this document may be subject to Export Control Regulations of the European Union, USA or other countries. Each recipient of this document is responsible for ensuring that transfer or use of any information contained in this document complies with all relevant Export Control Regulations. ECN N/A.

## DESCRIPTION

---

### **VibroSight® portable analyser**

The VibroSight® portable analyser, from Meggitt Sensing Systems' Vibro-Meter® product line, is a complete condition monitoring system that is ready-to-use out of the box. It is intended for use in industrial environments where the portability and ruggedness of the system are essential, and when a permanent installation is not required.

The portable analyser is a self-contained system that integrates a portable computer running the VibroSight® software and a XMV16 / XIO16T extended vibration monitoring card pair. VibroSight is a highly integrated and powerful software suite with outstanding capabilities that supports the condition monitoring of all machinery. The XMV16 / XIO16T is the same card pair that is proven in the well-established VM600 rack-based monitoring systems.

The computer and the card pair are fully enclosed in order to provide protection from mechanical shocks. The enclosure is made from aluminium and sheet metal to provide the ruggedness required for industrial environments but in a compact and lightweight form that makes the portable analyser suitable for mobile applications. In fact, the portable analyser's dimensions even allow it to be transported as hand luggage (carry-on cabin baggage) by most commercial airlines.

### **Portable computer**

The portable computer is tightly-integrated into the VibroSight portable analyser to optimise the use of space and features a powerful multi-core Intel® Core™ i7-620M mobile processor, 8 GB of DDR3 memory, a fast 500 GB hard disk, a DVD-RW drive, high-resolution 17.3" display and gigabit Ethernet.

Even with the XMV16 / XIO16T card pair installed, there are spare expansion bays and interfaces which allow the portable analyser to be freely configured for other applications.

The portable computer runs the Microsoft® Windows® 7 Professional (64-bit) operating system and comes with all of the software required for the effective condition monitoring of rotating machinery pre-installed. This includes the latest versions of the VibroSight software (Standard edition with support and maintenance for one year, and sixteen XMV16 channels enabled), and the associated Sybase® SQL Anywhere database software (required by VibroSight).

### **VibroSight software**

The VibroSight portable analyser runs the VibroSight software and is fully software configurable. It can be programmed to capture data using different acquisition modes: principal, auxiliary and/or direct mode. For example, the principal mode is typically used for continuous data acquisition at fixed intervals and is suitable for normal operation, increasing vibration levels and transients.

In addition to time, data acquisition can also be based on alarms, events, machine operating conditions or other system variables. Individual measurement channel parameters can be configured to provide the measurement data required by specific applications. For example, frequency bandwidth, time domain outputs, spectral resolution, windowing function, averaging, frequency domain outputs and measurement qualifiers (rectifiers) are all configurable. Refer to the *VibroSight software data sheet* for additional information.

### **XMV16 / XIO16T card pair**

The XMV16 / XIO16T extended vibration monitoring card pair provides all of the interfacing and signal processing functions required of an intelligent data acquisition system. These cards acquire and analyse vibration data, then communicate the results via gigabit Ethernet to the VibroSight software running on the portable computer. Both cards are fully software configurable.

The XMV16 card is a vibration monitoring card that performs analog to digital conversion and digital signal processing functions, including the processing required for each output. It acquires and processes data in high-resolution (24-bit ADC) to generate waveforms, spectra and up to 20 outputs per channel. The XIO16T is an input/output card that acts as a signal interface for the XMV16 card. It performs all of the analog signal conditioning and protects all inputs against signal surges and EMI to meet EMC standards. The card's inputs can accept signals representing speed and phase reference (for example, from TQ xxx sensors) and vibration derived from acceleration, velocity and displacement (for example, from CA xxx, CE xxx, CV xxx and TQ xxx sensors). Any dynamic or quasi-static signals that are appropriately signal conditioned can also be used.

High-density connectors with spring-loaded connections are used to connect measurement chain signals to the XIO16T card. Refer to the *XMV16 / XIO16T extended vibration monitoring card pair data sheet* for additional information.

**DESCRIPTION** *(continued)***Applications information**

The VibroSight portable analyser is a highly integrated and complete machinery monitoring system that is easy to use. It is a durable, economic and versatile solution that is suitable for machinery monitoring applications in a wide range of industries where a permanently installed condition monitoring system, such as a VM600 rack or a VibroSmart DMS, is not required.

The portable analyser can be quickly brought to any location on a site in order to troubleshoot machinery exhibiting a temporary issue such as increased

vibration or a loss of efficiency. For example, it can be used temporarily in order to allow run-up and coast-down data to be captured.

Tachometer and dynamic inputs cables are available that allow the portable analyser to be easily and quickly connected to the signals provided by an existing machinery protection system's BNC outputs (see Accessories on page 8).

For specific applications, contact your nearest Meggitt Sensing Systems representative.

**SPECIFICATIONS****Portable computer****Hardware**

Processor	: Intel Core™ i7-620M 2.66 GHz dual-core mobile processor, with Hyper-Threading and Turbo Boost technology
Chipset	: Mobile Intel QM57 Express, with vPro™ technology
Memory	: 8 GB DDR3 SDRAM (1066 MHz)
Internal storage (hard disk drive)	: 500 GB SATA II 2.5" HDD. Note: Approximately 400 GB of storage is available for user data, such as VibroSight Server databases. Additional storage can be connected via the expansion bays or USB.
Optical drive	: 8x DVD-RW (slot loading)
Graphics	: Integrated Intel HD Graphics (processor-based)
LCD display	
• <i>Size</i>	: 17.3" diagonal (16:9)
• <i>Resolution</i>	: 1920 x 1080
• <i>Brightness</i>	: 300 cd/m <sup>2</sup>
• <i>Contrast ratio</i>	: 500:1
• <i>Backlight MTBF</i>	: 10000 hours
Input devices	: Full-size 104-key QWERTY keyboard (US layout) and touchpad, integrated in the hinged panel of the enclosure
Communications	
• <i>Network adapter (LAN)</i>	: Gigabit Ethernet (1000BASE-T), up to 1000 Mbps (1 Gbps)
• <i>SATA</i>	: SATA II (3 Gbps)
• <i>USB</i>	: USB 2.0 (480 Mbps)
Ports and connectors (external)	
• <i>Power</i>	: AC power connector
• <i>Video</i>	: 1x HDMI and 1x DVI-D
• <i>Communications</i>	: 1x Ethernet 8P8C (RJ45) and 4x USB
Expansion bays	: 2x 2.5" drive bays (removable storage)

**SPECIFICATIONS** *(continued)*

---

**Software**

Operating system	: Microsoft Windows 7 Professional (64-bit)
Pre-installed software	
• <i>VibroSight 2.x.x</i> (Meggitt Sensing Systems)	: The VibroSight software supports the configuration, management and operation of the XMV6/XIO16T monitoring system hardware, including the use of VibroSight Vision for data visualisation and analysis.
• <i>SQL Anywhere 11.x.x</i> (Sybase)	: Database software required by VibroSight Server databases

**XMV16 / XIO16T card pair**

**Tachometer (speed and phase reference) channel inputs**

Number	: 4
Input range	
• <i>Voltage</i>	: $\pm 20 V_{DC}$ ( $\geq 100 k\Omega$ input impedance)
• <i>Current</i>	: $\pm 30 mA$ (200 $\Omega$ current measuring resistor)
Speed measurement	: 1 to 100 000 RPM (0.017 Hz to 1.667 kHz)
Speed measurement resolution	: 5 ns

**Dynamic (vibration) channel inputs**

Number	: 16
Input range	
• <i>Voltage</i>	: $\pm 30 V_{DC}$ ( $20 V_{DC} + 10 V_{AC}$ ) ( $\geq 200 k\Omega$ input impedance)
• <i>Current</i>	: $\pm 25 mA$ (100 $\Omega$ current measuring resistor)
Analog to digital converter	: 24-bit
Maximum sampling rate	: 98 kHz
Frequency bandwidth	
• <i>AC</i>	: 0.10 Hz to 38 kHz (HP filter at -3 dB). An optional (software configurable) high-pass filter can be added to the AC path to increase the HP cutoff frequency to 1.0, 3.0 or 10.0 Hz.
• <i>DC</i>	: DC to 1.0 Hz (LP filter at -3 dB)
Accuracy (amplitude)	: 1% of input FSD

**Signal processing**

Data acquisition	: Simultaneous data acquisition on all channels, configurable as asynchronous and/or synchronous sampling
Data acquisition modes	
• Principal mode	: This is the main data acquisition mode used to obtain waveforms, spectra and extracted data measurements continuously, for display in VibroSight Vision and logging to a VibroSight Server database. The update rate depends on the configured FFT resolution: 100 ms for 100 to 1600 lines, 200 ms for 3200 lines and 500 ms for 6400 lines.
• Auxiliary mode	: This is a complementary data acquisition mode used to obtain more detailed measurements (higher-resolution waveforms and spectra) at reduced update rates, for display in VibroSight Vision and logging to a VibroSight Server database
• Direct mode	: The direct data acquisition mode is used to obtain a digitised continuous long-duration waveform in the TDMS file format for the time leading up to an event, for display via third-party software

**SPECIFICATIONS** *(continued)*

Fixed frequency bandwidth (asynchronous)	: 40 Hz to 38 kHz (configurable)
Order tracking speed range (synchronous)	: 15 to 100000 RPM
Order tracking bandwidth (synchronous)	: 1.56, 3.125, 6.25, 12.5, 25, 50, 100, 200 and 400 orders
Sampling rate	: 2.56 x frequency bandwidth
Signal processing	: Single-channel and dual-channel processing with high SNR data processing and data quality checks
Alarm processing	: 5 configurable severities per processed output and 8 detection levels with hysteresis and time delay

**Outputs**

Waveform resolution	: Up to 16384 data points
FFT resolution	: Up to 6400 lines
FFT windows	: Rectangular, Hanning, Hamming, Flat top, Blackman and Blackman-Harris
Extracted data	: Up to 20 processed outputs per channel: amplitude, phase and/or frequency
Update rate	: Up to 100 ms

**Configuration**

XMV16 / XIO16T card pair	: The 16 dynamic vibration channels and 4 tachometer channels are all individually configurable, using VibroSight Configurator. Note: The computer uses an internal gigabit Ethernet network adapter to communicate with the XMV16 / XIO16T card pair using the XMV16's Ethernet port (the XIO16T's Ethernet port is disabled).
--------------------------	--

**XIO16T card connectors**

J1	: Reserved for future use.
J2	: Tachometer inputs (channels 1 to 4). Weidmüller 12-pin S2L header (male). Compatible with 12-pin B2L and B2CF plug-in connectors (female).
J3	: Dynamic inputs (channels 1 to 8). Weidmüller 24-pin S2L header (male). Compatible with 24-pin B2L and B2CF plug-in connectors (female).
J4	: Dynamic inputs (channels 9 to 16). Weidmüller 24-pin S2L header (male). Compatible with 24-pin B2L and B2CF plug-in connectors (female). Note: B2CF plug-in connectors are recommended for all new installations. See Recommendations for reliable connections on page 8.

**SPECIFICATIONS** *(continued)*

---

**General**

**Power supply (input)**

AC voltage : 100 to 240 V (50/60 Hz)  
Power consumption : 400 W max.

**Power supply (output)**

The VibroSight portable analyser does not include any power supply outputs and cannot be used to supply power to measurement chain devices such as sensors or signal conditioners.

**Thermal considerations**

The VibroSight portable analyser includes cooling fans (forced-air cooling)

**Environmental**

Temperature

- *Operating* : 0 to +40°C (32 to +104°F)
- *Storage* : -10 to +60°C (-14 to +140°F)

Humidity : 20 to 80% non-condensing

Protection rating : IP20  
(according to IEC 60529)

Vibration : 2 g RMS, 10 min per axis  
(according to MIL-PRF-28800F)

Shock : 30 g (half sine, 11 ms duration), 3 shocks in each of three orthogonal axes (18 shocks total)  
(according to MIL-PRF-28800F)

Altitude : 3000 m (9840 ft) max.  
Note: Reduced air density affects cooling ability.

**Approvals**

Conformity : CE marking and FCC compliance

Electrical safety : EN 61010-1 Edition 3 (2010), permanently connected equipment.  
EN 60950-1:2006+A11:2009 with amendment 1:2010+A12:2011  
and IEC 60950-1 Edition 2 (2005) with amendment 1 (2009),  
information technology equipment

Electromagnetic compatibility : CISPR 22, Class A limits.  
EN 55022 (2010), Class A ITE.  
EN 55024 (2010), Class A ITE.  
EN 61000-3-2 (2009).  
EN 61000-3-3 (2008).  
EN 61000-4-2 (2009).  
EN 61000-4-3 (2010).  
EN 61000-4-4 (2012).  
EN 61000-4-5 (2006).  
EN 61000-4-6 (2009).  
EN 61000-4-8 (2010).  
EN 61000-4-11 (2004).  
EN 61326-1 (2013), Class A.  
FCC Code of Federal Regulation (CFR) Title 47, Part 15, Subpart B,  
Class A digital device.

Other : Compliant with RoHS and WEEE directives

**SPECIFICATIONS** *(continued)*

**Physical**

- Construction : Aluminium alloy (frame) and sheet metal.  
Rugged outer casing with hinged panel that closes to protect the display and keyboard during transportation.
- Colour : Black
- Dimensions : See Mechanical drawings on page 7
- Weight : 8.25 kg (18.2 lb) approx.

**MECHANICAL DRAWINGS**

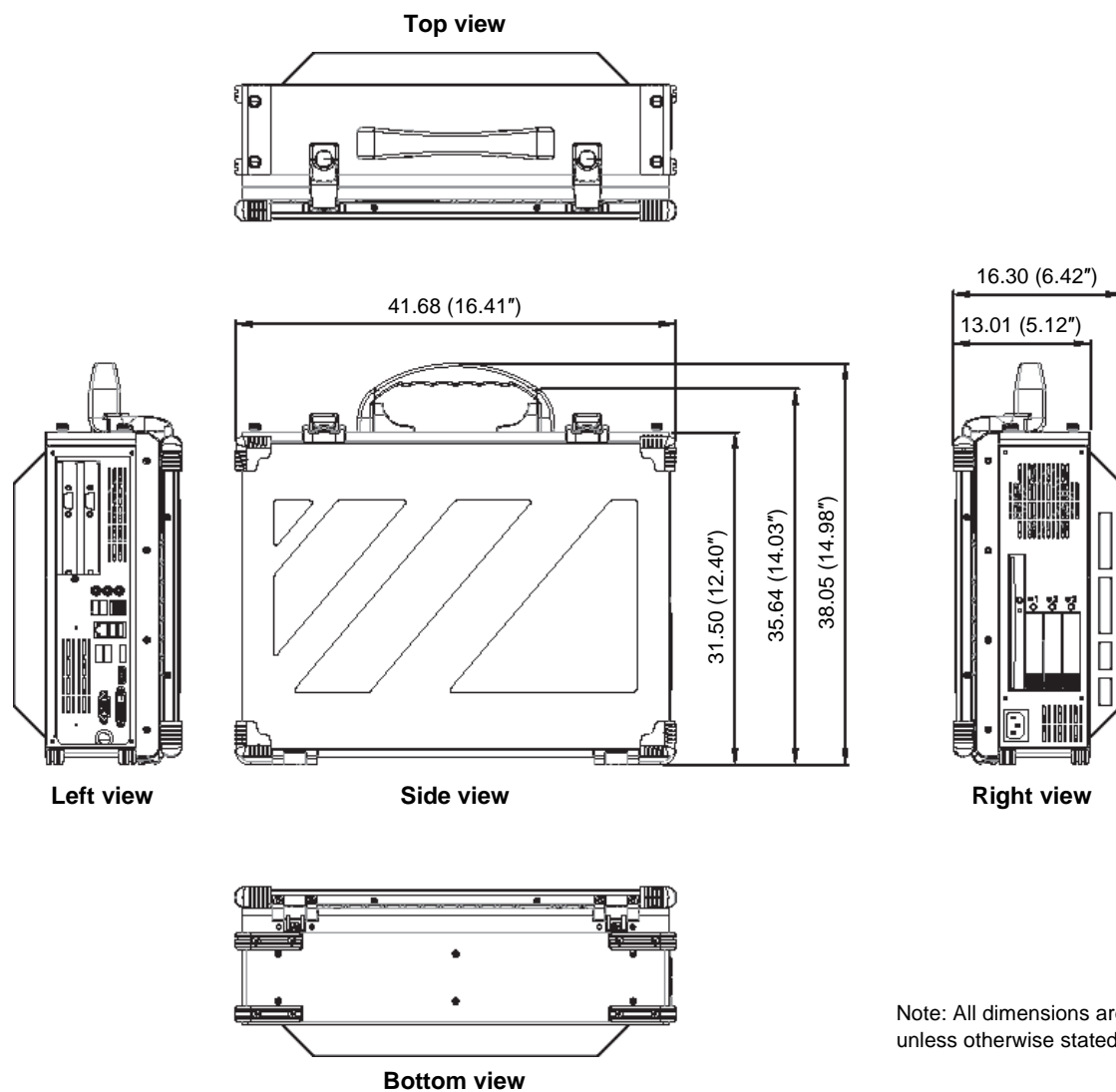

Note: All dimensions are in mm (in) unless otherwise stated.

## ORDERING INFORMATION

To order please specify

Type	Designation	Ordering number
VSPA	VibroSight portable analyser	600-021

The VibroSight portable analyser is supplied with:

- The latest available versions of VibroSight software, associated SQL Anywhere database software and XMV16 / XIO16T card hardware and firmware pre-installed, including all required prerequisites and updates.
- A VibroSight user licence for the Standard edition of the VibroSight software with support and maintenance for one year, and sixteen XMV16 channels enabled.
- A XIO16T wire-end ferrule kit (see Recommendations for reliable connections on page 8).
- A USB-to-SATA cable that allows any SATA-compatible storage device to be connected via a USB port (as an alternative to using a spare expansion bay).
- A padded trolley case (roll along) with integrated wheels, telescopic towing handle and external pocket.

## ACCESSORIES

Type	Designation	Ordering number
Hard case	Protective equipment case to provide additional environmental and mechanical protection during transportation (IP67 or equivalent)	Contact Meggitt Sensing Systems
1 TB HDD	1 TB SATA II 2.5" hard disk drive (for installation in a spare expansion bay)	962.02.22.1000
Tachometer inputs cable	Cable assembly (1.5 m) for use with the XIO16T's J1 or J2 connector (12-pin)	957.18.40.0617
Dynamic inputs cable	Cable assembly (1.5 m) for use with the XIO16T's J3 or J4 connector (24-pin)	957.18.40.0616

Note: As shown (right), one end of these 1.5 m cable assemblies uses a B2CF connector for connection to the XIO16T card, while the other end provides a male BNC connector for each input signal.



## RECOMMENDATIONS FOR RELIABLE CONNECTIONS

It is highly recommended to terminate all wires connected to the B2CF plug-in connectors used by J1, J2, J3 and J4 of the XIO16T card by crimping them with the ferrules supplied in the XIO16T wire-end ferrule kit, in order to help ensure consistent and reliable connections.

Refer to the VibroSight application note 007 *Interfacing to the XIO16T card: recommendations for reliable connections* and the *XIO16T Wire-end ferrule kit* instruction sheet for more information.

### RELATED PRODUCTS

---

VibroSight	Total monitoring solution software	: Refer to corresponding data sheet
XMV16 / XIO16T	Extended vibration monitoring card pair	: Refer to corresponding data sheet

Headquartered in the UK, Meggitt PLC is a global engineering group specializing in extreme environment components and smart sub-systems for aerospace, defence and energy markets.

Meggitt Sensing Systems is the operating division of Meggitt specializing in sensing and monitoring systems, which has operated through its antecedents since 1927 under the names of ECET, Endevco, Ferroperm Piezoceramics, Lodge Ignition, Sensorex, Vibro-Meter and Wilcoxon Research. Today, these operations are integrated under one strategic business unit called Meggitt Sensing Systems, headquartered in Switzerland and providing complete systems, using these renowned brands, from a single supply base.

The Meggitt Sensing Systems facility in Fribourg, Switzerland was formerly known as Vibro-Meter SA, but is now Meggitt SA. This site produces a wide range of vibration and dynamic pressure sensors capable of operation in extreme environments, leading-edge microwave sensors, electronics monitoring systems and innovative software for aerospace and land-based turbo-machinery.



All statements, technical information, drawings, performance rates and descriptions in this document, whilst stated in good faith, are issued for the sole purpose of giving an approximate indication of the products described in them, and are not binding on Meggitt SA unless expressly agreed in writing. Before acquiring this product, you must evaluate it and determine if it is suitable for your intended application. Unless otherwise expressly agreed in writing with Meggitt SA, you assume all risks and liability associated with its use. Any recommendations and advice given without charge, whilst given in good faith, are not binding on Meggitt SA.

Meggitt Sensing Systems takes no responsibility for any statements related to the product which are not contained in a current Meggitt Sensing Systems publication, nor for any statements contained in extracts, summaries, translations or any other documents not authored by Meggitt Sensing Systems. We reserve the right to alter any part of this publication without prior notice.

In this publication, a dot (.) is used as the decimal separator and thousands are separated by thin spaces. Example: 12345.67890.

#### Sales offices

Meggitt Sensing Systems has offices in more than 30 countries. For a complete list, please visit our website.



ISO 9001  
FS 584089



#### Your local agent

#### Head office

Meggitt SA  
Route de Moncor 4  
PO Box 1616  
CH - 1701 Fribourg  
Switzerland

Tel: +41 26 407 11 11  
Fax: +41 26 407 13 01

[www.meggittsensingystems.com](http://www.meggittsensingystems.com)  
[www.vibro-meter.com](http://www.vibro-meter.com)